

Triple Integrals in Cylindrical and Spherical Coordinates

Objective:

1. Cylindrical and spherical coordinates
2. Triple integrals in cylindrical coordinates
3. Triple integrals in spherical coordinates

I. Cylindrical and Spherical Coordinates

In two dimensions we studied two coordinate systems: **Rectangular** and **Polar coordinates**. Each will give a convenient description of certain **curves and regions**. Each point in plane geometry is associated with a pair of real numbers and every pair of real numbers determines a point.

In three dimensions we will study three coordinate systems: **Rectangular**, **Cylindrical** and **Spherical coordinates**. Each will give a convenient description of some commonly occurring **surfaces and solids**. Each point in space is associated with a triple of real numbers (the coordinates of the point) and every triple of real numbers determines a point.

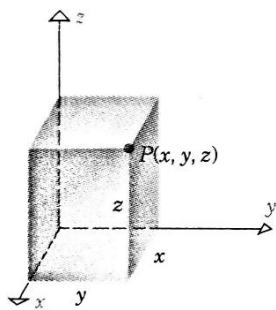

Rectangular Coordinates
 (x, y, z)

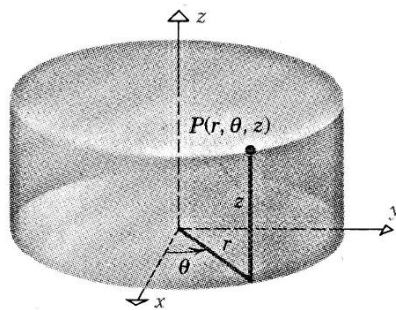

Cylindrical Coordinates
 (r, θ, z)

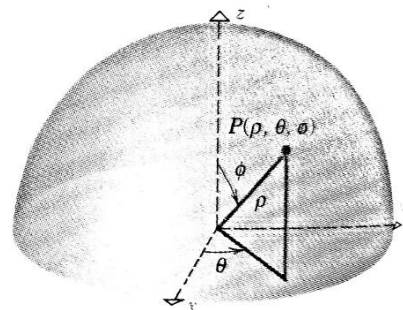

Spherical Coordinates
 (ρ, θ, ϕ)
 $\rho \geq 0, 0 \leq \phi \leq \pi$

Spherical coordinates are related to longitude and latitude coordinates used in navigation. Suppose the center of earth is at the origin, the positive z-axis passes through the north pole, and the positive x-axis passes through the prime meridian*. If we assume the earth to be a perfect sphere of radius $\rho = 4000$ miles, then each point on the earth has spherical coordinates of the form $(4000, \theta, \phi)$, where θ determines longitude and ϕ latitude of the point.

For example, Highline College is at $(4000, 47.3882^\circ N, 122.3018^\circ W)$

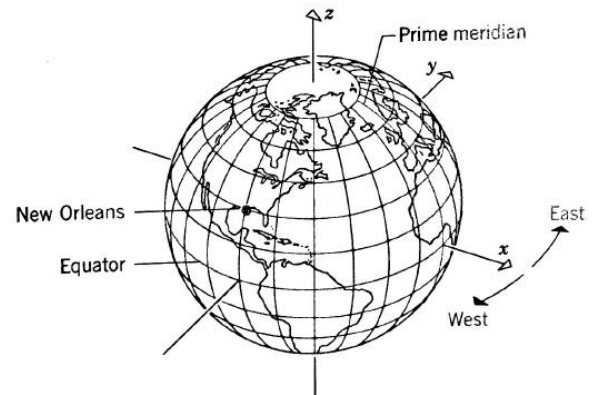

*The prime meridian is ultimately arbitrary, unlike the equator, which is determined by the axis of rotation. Various conventions have been used or advocated in different regions and throughout history. The most widely used modern meridian is the IERS Reference Meridian. It is derived but deviates slightly from the Greenwich Meridian, which was selected as an international standard in 1884. This great circle divides the sphere, e.g., the Earth, into two hemispheres. If one uses directions of East and West from a defined prime meridian, then they can be called the Eastern Hemisphere and Western Hemisphere.

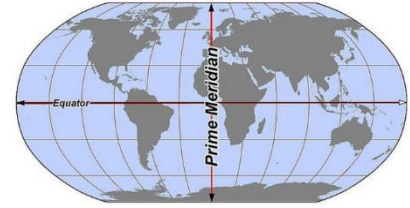

The following graph show you another presentation of a point in the three coordinate systems.

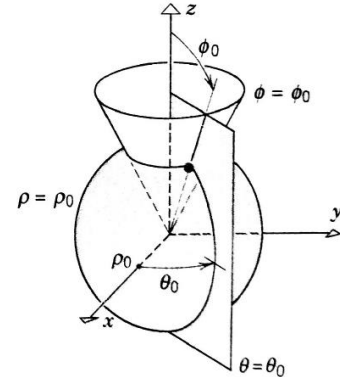
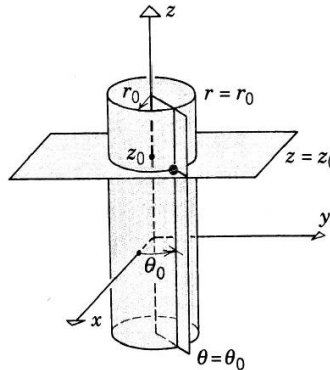
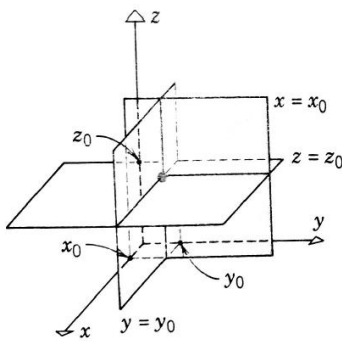

Ex1: What does each equation represents?

E-book visual aid

In a rectangular coordinates:

- $x = x_0$

- $y = y_0$

- $z = z_0$

In a cylindrical coordinates:

- $r = r_0$

- $\theta = \theta_0$

- $z = z_0$

In a spherical coordinates:

- $\rho = \rho_0$

- $\theta = \theta_0$

- $\phi = \phi_0$

To change the coordinates of a point from one system to another, you can use these formulas:

CONVERSION	FORMULAS
$(r, \theta, z) \rightarrow (x, y, z)$	$x = r \cos \theta, \quad y = r \sin \theta, \quad z = z$
$(x, y, z) \rightarrow (r, \theta, z)$	$r = \sqrt{x^2 + y^2}, \quad \tan \theta = y/x, \quad z = z$
$(\rho, \theta, \phi) \rightarrow (r, \theta, z)$	$r = \rho \sin \phi, \quad \theta = \theta, \quad z = \rho \cos \phi$
$(r, \theta, z) \rightarrow (\rho, \theta, \phi)$	$\rho = \sqrt{r^2 + z^2}, \quad \theta = \theta, \quad \tan \phi = r/z$
$(\rho, \theta, \phi) \rightarrow (x, y, z)$	$x = \rho \sin \phi \cos \theta, \quad y = \rho \sin \phi \sin \theta, \quad z = \rho \cos \phi$
$(x, y, z) \rightarrow (\rho, \theta, \phi)$	$\rho = \sqrt{x^2 + y^2 + z^2}, \quad \tan \theta = y/x, \quad \cos \phi = z/\sqrt{x^2 + y^2 + z^2}$

These are the results of some algebraic manipulations:

Cylindrical coordinates

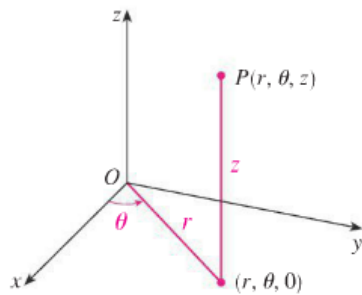

$$x = r \cos \theta \quad y = r \sin \theta \quad z = z$$

$$r^2 = x^2 + y^2 \quad \tan \theta = \frac{y}{x} \quad z = z$$

Spherical coordinates

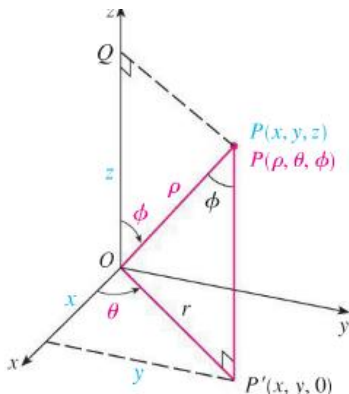

$$x = \rho \sin \phi \cos \theta \quad y = \rho \sin \phi \sin \theta \quad z = \rho \cos \phi$$

$$\rho^2 = x^2 + y^2 + z^2$$

Ex2: Graph $\left(4, \frac{\pi}{3}, -3\right)$ in cylindrical coordinates then find its rectangular coordinates representation.

Ex3: Find the equation in cylindrical coordinates of the surface whose equation in rectangular coordinates is $z = x^2 + y^2 - 2x + y$.

Ex4: Find an equation in rectangular coordinates of the surface whose equation in cylindrical coordinate is $r = 4 \cos \theta$. What does it represent?

Ex5: Find the rectangular coordinates of the point whose spherical coordinates are $\left(4, \frac{\pi}{3}, \frac{\pi}{4}\right)$.

Ex6: Find an equation of a paraboloid $z = x^2 + y^2$ in spherical coordinates.

Triple integrals in cylindrical coordinates

Cylindrical coordinates are useful in problems that involve symmetry about an axis, and the z -axis is chosen to coincide with this axis of symmetry. For instance, the axis of the circular cylinder with Cartesian equation $x^2 + y^2 = c^2$ is the z -axis. In cylindrical coordinates this cylinder has the very simple equation $r = c$. (See Figure 4.) This is the reason for the name “cylindrical” coordinates.

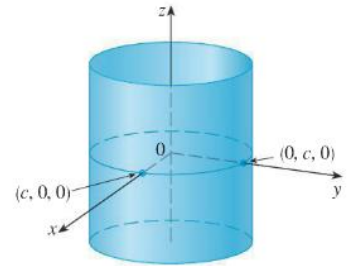

FIGURE 4

4
$$\iiint_E f(x, y, z) \, dV = \int_{\alpha}^{\beta} \int_{h_1(\theta)}^{h_2(\theta)} \int_{u_1(r \cos \theta, r \sin \theta)}^{u_2(r \cos \theta, r \sin \theta)} f(r \cos \theta, r \sin \theta, z) \, r \, dz \, dr \, d\theta$$

Formula 4 is the **formula for triple integration in cylindrical coordinates**. It says that we convert a triple integral from rectangular to cylindrical coordinates by writing $x = r \cos \theta$, $y = r \sin \theta$, leaving z as it is, using the appropriate limits of integration for z , r , and θ , and replacing dV by $r \, dz \, dr \, d\theta$. (Figure 7 shows how to remember this.) It is worthwhile to use this formula when E is a solid region easily described in cylindrical coordinates, and especially when the function $f(x, y, z)$ involves the expression $x^2 + y^2$.

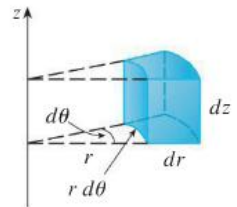
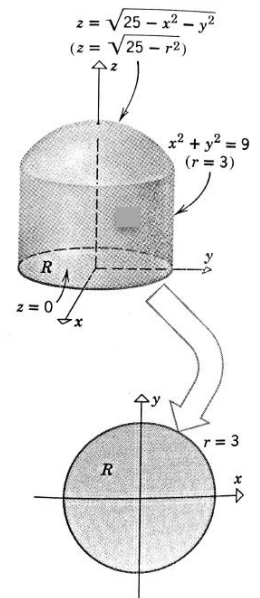

FIGURE 7

Volume element in cylindrical coordinates: $dV = r \, dz \, dr \, d\theta$

Ex7: Use triple integration in cylindrical coordinates to find the volume of the solid that is bounded above by the hemisphere $z = \sqrt{25 - x^2 - y^2}$, below by the xy -plane, and laterally by the cylinder $x^2 + y^2 = 9$.



Ex8: Use cylindrical coordinates to evaluate $I = \int_{-3}^3 \int_{-\sqrt{9-x^2}}^{\sqrt{9-x^2}} \int_0^{9-x^2-y^2} x^2 dz dy dx$

2. Triple integrals in spherical coordinates

The spherical coordinate system is especially useful in problems where there is symmetry about a point, and the origin is placed at this point. For example, the sphere with center the origin and radius c has the simple equation $\rho = c$ (see Figure 2); this is the reason for the name “spherical” coordinates. The graph of the equation $\theta = c$ is a vertical half-plane (see Figure 3), and the equation $\phi = c$ represents a half-cone with the z -axis as its axis (see Figure 4).

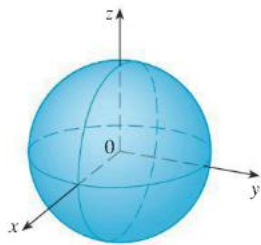

FIGURE 2 $\rho = c$, a sphere

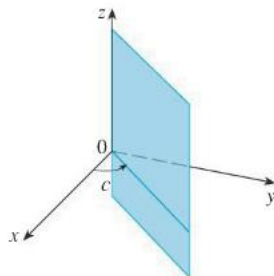

FIGURE 3 $\theta = c$, a half-plane

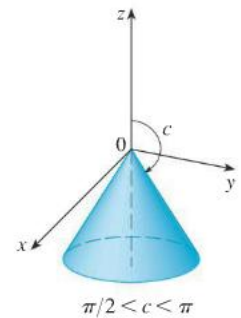
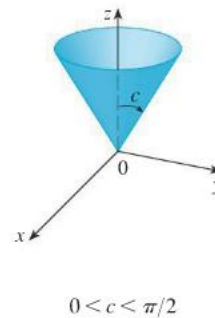

FIGURE 4 $\phi = c$, a half-cone

Formula 3 is the **formula for triple integration in spherical coordinates**.

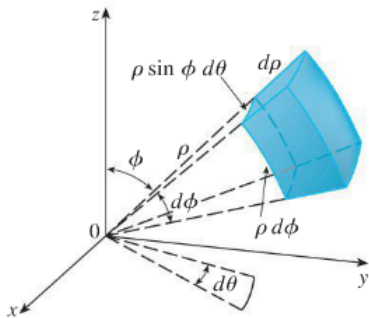

FIGURE 8

Volume element in spherical coordinates: $dV = \rho^2 \sin \phi \, d\rho \, d\theta \, d\phi$

$$\begin{aligned} \text{3} \quad \iiint_E f(x, y, z) \, dV \\ = \int_c^d \int_\alpha^\beta \int_a^b f(\rho \sin \phi \cos \theta, \rho \sin \phi \sin \theta, \rho \cos \phi) \rho^2 \sin \phi \, d\rho \, d\theta \, d\phi \end{aligned}$$

where E is a spherical wedge given by

$$E = \{(\rho, \theta, \phi) \mid a \leq \rho \leq b, \alpha \leq \theta \leq \beta, c \leq \phi \leq d\}$$

Formula 3 says that we convert a triple integral from rectangular coordinates to spherical coordinates by writing

$$x = \rho \sin \phi \cos \theta \quad y = \rho \sin \phi \sin \theta \quad z = \rho \cos \phi$$

using the appropriate limits of integration, and replacing dV by $\rho^2 \sin \phi \, d\rho \, d\theta \, d\phi$. This is illustrated in Figure 8.

This formula can be extended to include more general spherical regions such as

$$E = \{(\rho, \theta, \phi) \mid \alpha \leq \theta \leq \beta, c \leq \phi \leq d, g_1(\theta, \phi) \leq \rho \leq g_2(\theta, \phi)\}$$

In this case the formula is the same as in (3) except that the limits of integration for ρ are $g_1(\theta, \phi)$ and $g_2(\theta, \phi)$.

Usually, spherical coordinates are used in triple integrals when surfaces such as cones and spheres form the boundary of the region of integration.

Ex9: Use spherical coordinates to find the volume of the solid bounded above by the sphere

$$x^2 + y^2 + z^2 = 16 \text{ and below by the cone } z = \sqrt{3(x^2 + y^2)}.$$

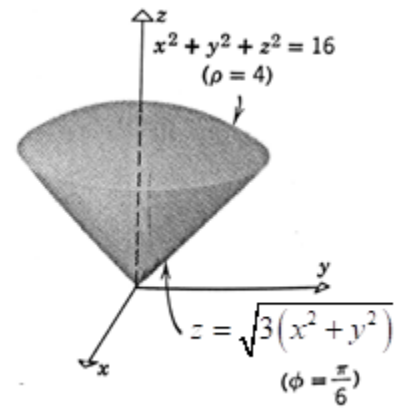

Ex10: Use spherical coordinates to evaluate $I = \int_{-2}^2 \int_{-\sqrt{4-x^2}}^{\sqrt{4-x^2}} \int_0^{\sqrt{4-x^2-y^2}} z^2 \sqrt{x^2 + y^2 + z^2} dz dy dx$